

FMR R-SERIES SPRAYER 2300RT GEN II



INNOVATION FOR GROWTH.

FMR R-SERIES SPRAYER 2300RT GEN II

The Generation II R-Series Recycling Sprayer takes a great concept and makes it even better! Building on the original award winning R-Series released in 2010, the Generation II machine introduces a number of new features and innovations that make owning and operating this machine in your vineyard even more beneficial.

New features include:

- New shroud design with fold down sump in base for rapid cleaning of filtration screens
- New shroud design is quickly and easily dismantled for ease of servicing
- Tank design provides improved weight distribution for stability
- New boom system provides improved functionality and flexibility
- Pumps and valves slide or fold out, making servicing simple and easy
- Overall maneuverability and stability improved with overall height and length reduced and centre of mass lowered
- New heavy duty tandem axle with suspension system
- Improved tank level indicator located on rear frame
- Improved hydraulic system for greater efficiency and function
- Customized Bravo 300S Auto rate controller for improved operator comfort and control

FEATURES:

- 2300lt Composite tank
- 200lt fresh water for flushing & hand wash
- Hot dip galvanised chassis & boom
- Weber tangential fans with 8 nozzle wet boom
- Bravo 300 Automatic rate controller
- Proven R-Series delivery & recycling technology
- 100% hydraulic drive - just 45lt/min required

BENEFITS:

- Addresses the environmental and social issues from off-target drift
- Enables savings of 25-40% of annual spray expenditure
- Huge savings in time from reduced refill occasions
- Increased application opportunity due to ability to operate in inclement weather conditions
- Multiple systems for enhanced operator comfort and safety

The only vineyard sprayer that really contributes to your 'Triple Bottom Line'

MODEL DIMENSIONS:

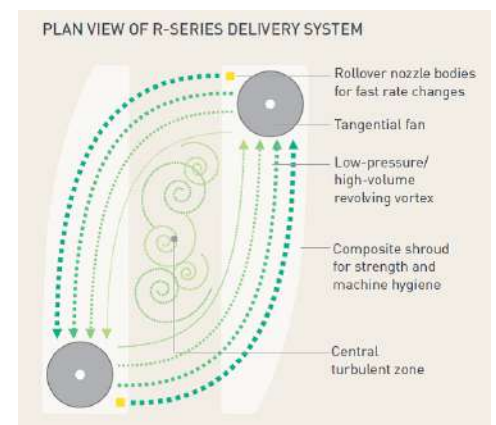
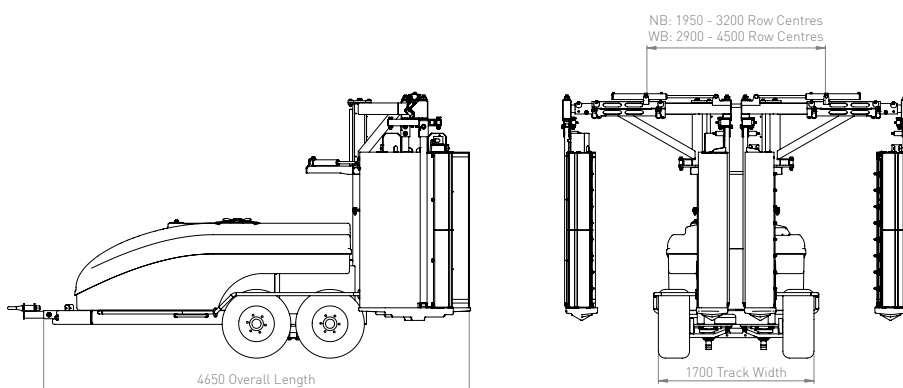

FMR GROUP LIMITED NEW ZEALAND

2 Warwick Street, Mayfield, Blenheim 7201, New Zealand
Postal Address : PO Box 158, Blenheim 7240, New Zealand
Telephone : +64 3 572 5150 | Freephone: 0800 367 583
Email: info@fmrgroup.co.nz | FMRGROUP.CO.NZ

FMR GROUP LIMITED AUSTRALIA

53 Oborn Road, Mount Barker, South Australia 5251, Australia
Postal Address : PO Box 1059, Mount Barker 5251, Australia
Telephone : +61 8 8391 5947 | Freephone: 1800 269 773
Email: info@fmrgroup.com.au | FMRGROUP.COM.AU

